

ALL DIMENSIONS ARE IN MM. UNLESS OTHERWISE SPECIFIED

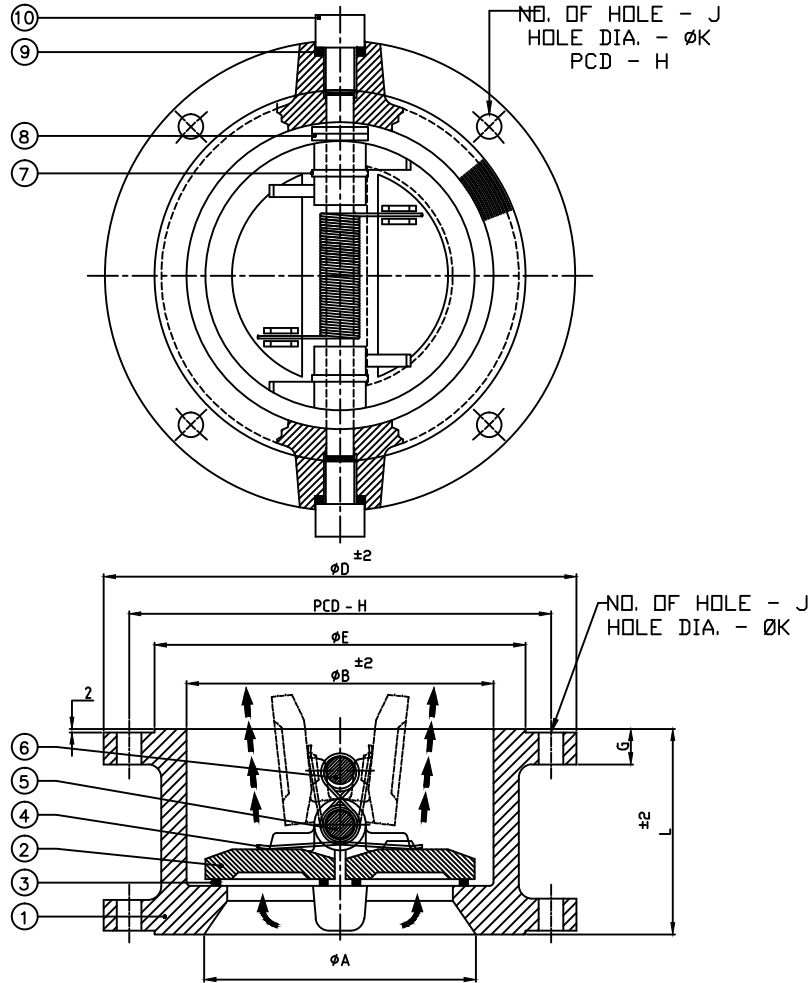

TEST PRESSURE, $\text{kg/cm}^2$		
TESTING	BODY	SEAT
HYDRAULIC	32	22

Technical Data

Manufacturing Standard: API 6D/API 594  
 Wall Thickness: API 594, 150#  
 Face to Face: API 6D/ASME B16.10, 150#  
 End Connection: FLANGED AS PER ASME B16.5, 150#  
 Inspection and Testing: API 6D/API 598

CLIENT. :-	--
ENQ. No.	--

SIZE	RATING	L	ØA	ØB	ØD	ØE	G	J	KØ	H	Tag.No.	QTY.
50MM	150#	60	51	65	150	92	16.3	04	19	120.7	--	--
	300#	60	51	65	165	92	22.7	08	19	127	--	--
65MM	150#	67	65	76	180	105	17.9	04	19	139.7	--	--
	300#	67	65	76	190	105	25.9	08	22.2	149.2	--	--
80MM	150#	73	80	92	190	127	19.5	04	19	152.4	--	--
	300#	73	80	92	210	127	29.0	08	22.2	168.3	--	--
100MM	150#	73	100	113	230	157	24.3	08	19	190.5	--	--
	300#	73	100	113	255	157	32.2	08	22.2	200.0	--	--
150MM	150#	98.5	152	163	280	216	25.9	08	22	241.3	--	--
	300#	98.5	152	163	320	216	37	12	22.2	269.9	--	--
200MM	150#	127	203	204	345	270	29	08	22	298.5	--	--
	300#	127	203	204	380	270	41.7	12	25.4	330.2	--	--
250MM	150#	146	254	262	405	324	30.6	12	25.4	362	--	--
	300#	146	254	262	445	324	48.1	16	28.57	387.4	--	--
300MM	150#	181	305	315	485	381	32.2	12	25.4	431.8	--	--
	300#	181	305	315	520	381	51.3	16	31.75	450.8	--	--
350MM	150#	184	350	363	535	412.8	35.4	12	28	476.3	--	--
	300#	222	350	363	585	412.8	54.4	20	31.75	514.4	--	--
400MM	150#	191	400	407	595	469.9	37	16	28	539.8	--	--
	300#	232	400	407	650	469.9	57.6	20	34.92	571.5	--	--
450MM	150#	203	450	465	635	533.4	40.1	16	32	577.9	--	--
	300#	264	450	465	710	533.4	60.8	24	34.92	628.5	--	--
500MM	150#	219	500	510	700	584.2	43.3	20	32	635	--	--
	300#	292	500	510	775	584.2	64.0	24	34.92	685.8	--	--
600MM	150#	222	600	610	815	692.2	48.1	20	34	749.3	--	--
	300#	318	600	610	915	692.2	70.3	24	41.27	812.8	--	--

NOTE :- ALL DIMENSION ARE IN MM.

P.No.	Qty.	Nomenclature	Material
10	4	PLUGS	CARBON STEEL
9	4	SEALS	PTFE
8	Req.	BODY LUG BEARINGS	AISI 410
7	Req.	PLATE LUG BEARINGS	AISI 410
6	1	STOP PIN	AISI 410
5	1	HINGE PIN	AISI 410
4	Req.	SPRING	AISI 410
3	2	SEAT	NITRILE RUBBER/ EPDM
2	2	CLOSURE PLATES	ASTM A-217 CA15
1	1	BODY	ASTM A-216 Gr.WCB

### Engineers Combine

I-18, Sayona Industrial Estate, Near Memco  
Char Rasta, Naroda Road, Ahmedabad-380025.

DRAWN BY	CHD. BY	APPD. BY	DATE
MAH.			27-01-17
MAT. WCB/SS		TITLE: DUAL PLATE CHECK VALVE	
SHEET 01 OF 01		FLANGE END 150# & 300# SIZE- 50TO600MM	
PROJECTION		DRG. NO. EC - DP. CK. VL.-50-600-03	
		FILE : E:\	